

# Model 924B Magnetostrictive Probe

## Inventory Measurement and In-Tank Leak Detection

All stainless-steel construction, highly accurate, easy installation and trouble-free performance for reliable inventory management and in-tank leak detection.

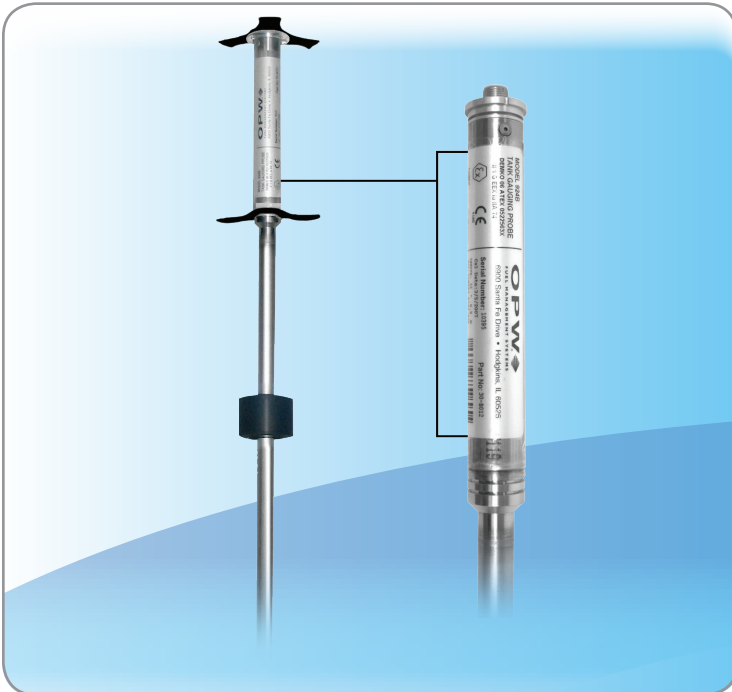

### The 924B Probe Magnetostrictive Probe

The 924B Magnetostrictive Probe features standard stainless-steel construction, making it the ideal inventory measurement solution for gasoline, diesel, ethanol and biodiesel applications. Available in lengths from 53 inches (135 cm) to 149 inches (379 cm), OPW 924B probes are designed to provide accurate fuel level readings no matter the size of your tanks.

### Applications

- ◆ As a level 1 probe, the 924B meets the needs of all tank applications
- ◆ Up to four probes can be connected on a single I.S. module (compatible gauges only)
- ◆ Certified to meet the U.S. Environmental Protection Agency's performance standards for 0.1 gph (0.38 L/hr) volumetric tank tightness testing and 0.2 gph (0.76 L/hr) monthly product-level monitoring



#### PRECISE

Capable of measuring product level changes to a resolution of 0.0005 inches (0.0127 mm)



#### RELIABLE

Optional Density Floats provide a measure of all changes in product density within a specified API density range



#### EASY INSTALLATION

Streamlined installation process ensures simple installation in both 2-inch and 4-inch riser systems



#### DURABLE

A rugged stainless-steel design prevents in-tank degradation and welded construction eliminates potential leak points

**Contact your OPW representative to learn more about the Model 924B Magnetostrictive Probe today!**

Phone: (708) 485-4200 ◆ Fax: (708) 485-4630 ◆ 6900 Santa Fe Drive ◆ Hodgkins, Illinois USA 60525 ◆ [www.opwglobal.com](http://www.opwglobal.com)

# Model 924B Magnetostrictive Probe

## Magnetostrictive Probe Data

- Measures product level changes to a resolution of 0.0005 inches (0.0127 mm)
- Measures product temperature changes to a resolution of 0.2°F (0.1°C)
- Measures water level changes to a resolution of 0.012 inches (0.254 mm)
- Linearity over the entire probe length is ± 0.04 inches (± 1 mm)

## Leak Test Performance

- EPA Static Leak and Continuous Test Certified
- 0.2 gph (0.76 L/hr) Statistical Leak Detection (SLD) Test  
Note: Only available in SiteSentinel® iSite™ and Integra™ tank gauges, 397,000 gallons (1,502,809 liters)/month throughput for single-tank, 2-tank or 3-tank manifold installations; 30,000-gallon (113,562-liter) combined maximum capacity
- 0.2 gph (0.76 L/hr) Statistical Leak Detection (SLD) Test: 99.1% Pd, 0.9% Pfa
- Third-party certified to meet U.S. EPA Static Leak Detection requirements in tanks up to 20,000 gallons (76,000 liters)
- 0.2 gph (0.76 L/hr) Static Leak Test: 98.18% Pd, 1.82% Pfa
- 0.1 gph (0.38 L/hr) Static Leak Test: 96.5% Pd, 3.5% Pfa
- 0.2 gph (0.76 L/hr) Automatic Leak Detection (ALD)
- 0.1 gph (0.38 L/hr) Automatic Leak Detection (ALD)

## Certifications & Accreditation

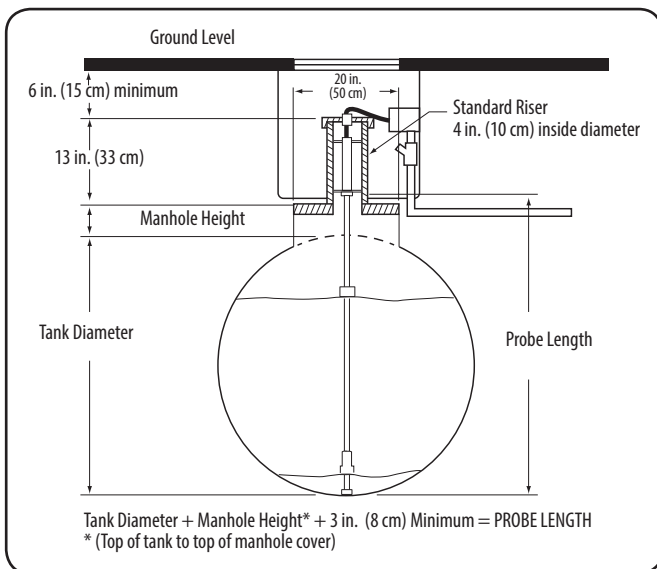

## Probe Length

Part No.	Description	Part No.	Description
30-B053	53 inch (135 cm)	30-B105	105 inch (267 cm)
30-B069	69 inch (175 cm)	30-B113	113 inch (287 cm)
30-B077	77 inch (196 cm)	30-B125	125 inch (318 cm)
30-B089	89 inch (226 cm)	30-B137	137 inch (348 cm)
30-B101	101 inch (257 cm)	30-B149	149 inch (379 cm)

## Probe Float Kits

Part No.	Description
30-1509-02	2 inch (5.1 cm) Gas/Water Nitrophenyl Float Kit
30-1509-01	2 inch (5.1 cm) Diesel/Water Nitrophenyl Float Kit
30-3232	2 inch (5.1 cm) Density Measurement Kit

Stainless-steel floats available upon request.

Note: No leak testing available with stainless-steel floats.

## Probe Specifications

- Type: Magnetostrictive/Float
- Material: Stainless-Steel Body, Nickel-Coated Brass Cap
- Location: Hazardous, Class 1, Division 1, Group D
- Temperature: 5 RTDs
- Temperature Range: -40° F to 158° F (-40° C to +70° C) At Pi: 1W
- Data Cable: 1,000 feet (305 m) Belden 88760  
500 feet (152 m) maximum of Belden 88761

OPW LPG Floats and Density Measurement Sensors are not certified for applications in which they will be subjected to pressures at or above 300 PSI. Pressures higher than 300 PSI will damage the devices, preventing them from providing accurate measurements.

## I.S. Barrier Wiring Diagram

